

Diaphragm seal with sterile connection For sanitary applications Model 990.50, NEUMO BioConnect®

WIKA data sheet DS 99.50



for further approvals
see page 3

Applications

- Food and beverage production
- Pharmaceutical industry, biotechnology industry, production of active ingredients
- Production of aseptic basic materials in the chemical industry

Special features

- Quick cleaning of measuring point, without residue
- Certified hygienic design
- Suitable for SIP and CIP
- EHEDG certified and 3-A compliant



Diaphragm seal with sterile connection, model 990.50
Fig. left: With grooved union nut
Fig. right: Flange connection

Description

Diaphragm seals are used to protect the pressure measuring instrument from aggressive, adhesive, crystallising, corrosive, highly viscous, environmentally hazardous or toxic media. A diaphragm made of the appropriate material provides for the separation from the medium to be measured. Thus even the most difficult measuring requirements can be met by combining measuring instruments with diaphragm seals.

A fluid inside the system, which can be chosen to suit the particular application, hydraulically transmits the pressure to the measuring instrument.

Almost limitless application possibilities exist due to the large number of available variants, such as diaphragm seal designs or materials. The type of process connection (flange, threaded and sterile connection) and the basic method of manufacture are important design differentiation criteria.

For further technical information on diaphragm seals and diaphragm seal systems see IN 00.06 "Application, operating principle, designs".

The model 990.50 NEUMO BioConnect® diaphragm seal is ideally suited to fulfil the high standard requirements of sanitary applications. It can be optimally integrated into pipelines via the BioConnect® fittings, fulfils all hygienic design requirements and is EHEDG certified. The diaphragm seal systems can withstand the cleaning vapour temperatures occurring in the SIP processes and thus ensure a sterile connection between the medium to be measured and the diaphragm seal.

Assembly of the diaphragm seal and measuring instrument is made via a direct assembly as standard or optionally via a cooling element or a flexible capillary.

For the material selection WIKA offers a variety of solutions, in which the upper body and the diaphragm are made of identical materials. Stainless steel 316L (1.4435) is used as standard material, other special materials are available on request.

Measuring systems with the model 990.50 WIKA diaphragm seal are successfully used in the life science industry, in pharmaceutical and biotechnology applications.

Standard version

Type of process connection

NEUMO BioConnect® connection

- Flange form R
- Thread with grooved union nut
- Clamp connection form R

For pipes per DIN 11866 row A and row B (or DIN 11850 and DIN EN ISO 1127)

For exact designs and nominal widths see tables on page 4 to 6

Nominal pressure

Flange connection: PN 70 bar
Threaded connection: PN 16 bar
Clamp connection: PN 16 bar (to DN 50)
PN 10 bar (from DN 65)

Measuring ranges

Flange connection: 0 ... 0.6 to 0 ... 70 bar
Threaded connection: 0 ... 0.6 to 0 ... 16 bar
Clamp connection: 0 ... 0.6 bar to 0 ... 16 bar (to DN 50)
0 ... 0.6 bar to 0 ... 10 bar (from DN 65)

(also vacuum and +/- measuring ranges)

Material of upper body

Stainless steel 1.4435 (316 L)

Material of wetted parts

Diaphragm: Stainless steel 1.4435 (316L)

Surface roughness of wetted parts

$R_a \leq 0.76 \mu\text{m}$ per ASME BPE SF3 (except for weld seam)

Level of cleanliness of wetted parts

Oil and grease free per ASTM G93-03 level E (WIKA standard) and ISO 15001 ($< 550 \text{ mg/m}^2$)

Connection to the measuring instrument

Axial weld-in connection

Options

- Process connection
 - Flange form V
 - Threaded coupling, male thread
 - Clamp connection form V
- Higher nominal pressures on request
- Surface roughness of wetted parts
 $R_a \leq 0.38 \mu\text{m}$ per ASME BPE SF4, only with electropolished surface (except for weld seam)
- Connection to the measuring instrument
G 1/2, G 1/4, 1/2 NPT or 1/4 NPT (female)
- Origin of wetted parts (EU, CH, USA)
- Marking of the diaphragm seal in accordance with the applicable 3-A standard

Installation example

Diaphragm seal, sterile connection, model 990.50 with directly assembled pressure gauge on a pipe socket

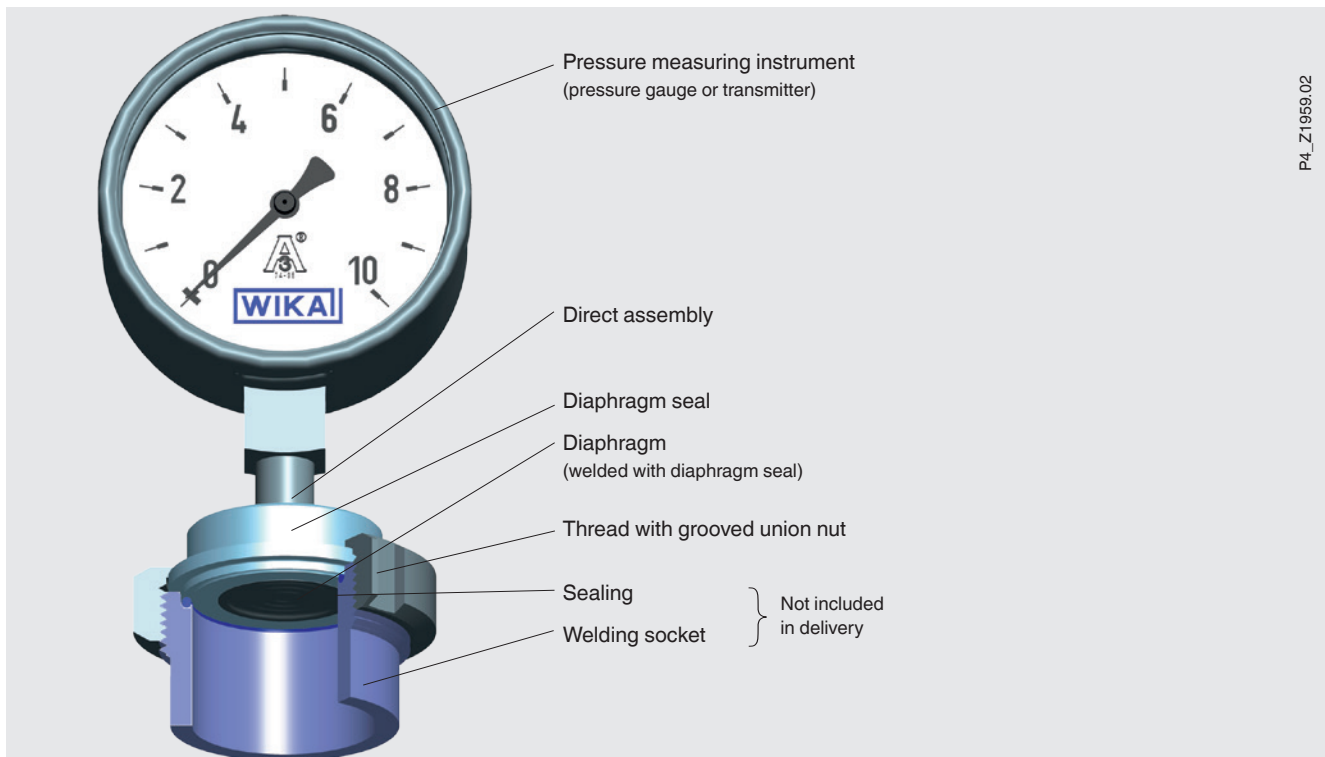

Additional information for diaphragm seal systems

See Technical information IN 00.06 “Diaphragm seals, application, operating principle, designs”

- Pressure measuring instrument model
- Connection to the measuring instrument: Direct assembly (calibrated in vertical mounting position, process connection facing downwards)
- Process temperature
- Ambient temperature
- System fill fluid
 - Recommendation for the food and beverage production: Neobee® KN 59 (FDA 21 CFR 172.856, 21 CFR 174.5)
 - Recommendation for pharmaceutical and cosmetics applications: Medicinal white mineral oil KN 92 (FDA 21 CFR 172.878, 21 CFR 178.3620(a); USP, EP)

Options for diaphragm seal systems

- Connection to the measuring instrument via cooling element or capillary
- Vacuum service (suitable for vacuum operation)
- Higher level of cleanliness of wetted parts
Oil and grease free per ASTM G93-03 level C and ISO 15001 (< 66 mg/m²)
- Height difference between measuring point and pressure measuring instrument with capillary in metre increments (max. 7 m with silicone oils/edible oils)
- Mounting bracket (required for connection to the measuring instrument via capillary, model 910.16, data sheet AC 09.07)
 - Form H per DIN 16281, 100 mm, aluminium, black
 - Form H per DIN 16281, 100 mm, stainless steel
 - Bracket for pipe mounting, for pipe Ø 20 ... 80 mm, steel

Materials

Upper body	Wetted part: Diaphragm
Standard	
Stainless steel 1.4435 (316L)	Stainless steel 1.4435 (316L)
Option	
Stainless steel 1.4435 (316L), electropolished	Stainless steel 1.4435 (316L), electropolished
Stainless steel 1.4539 (904L)	Stainless steel 1.4539 (904L)
Hastelloy C276 (2.4819)	Hastelloy C276 (2.4819)
Hastelloy C22 (2.4602)	Hastelloy C22 (2.4602)

Further material combinations on request

Dimensions in mm

Type of process connection: NEUMO BioConnect® connection

Pipe standard: Pipes per DIN 11866 row A and row B (or DIN 11850 und DIN EN ISO 1127)

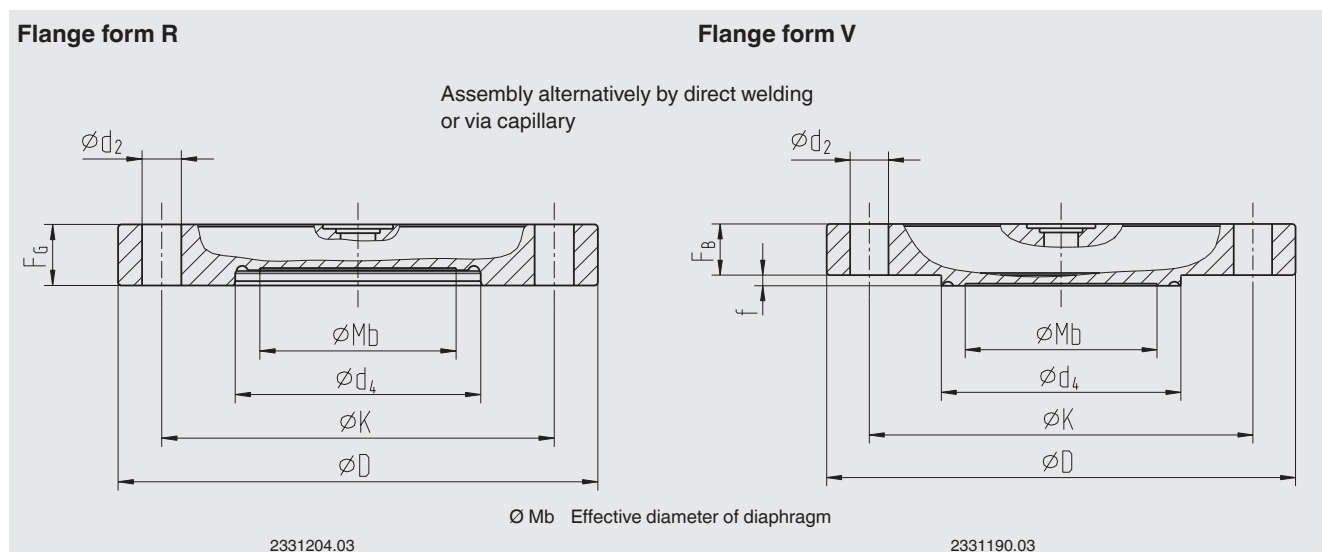

Flange form R

Model	DN	Dimensions in mm						Weight in kg
	in mm	Mb	D	F _G	k	d ₂	d ₄	
990.50 for pipes per DIN 11866 row A or DIN 11850 row 2	25	22	85	12	65	4 x Ø 9	32.3	0.5
	32	25	95	12	75	4 x Ø 9	38.3	0.6
	40	32	100	12	80	4 x Ø 9	44.3	0.7
	50	45	110	14	90	4 x Ø 9	56.3	1.0
	65	59	140	16	115	4 x Ø 11	72.3	1.8
	80	72	150	16	125	8 x Ø 11	87.3	2.0
990.50 for pipes per DIN 11866 row B or DIN EN ISO 1127 row 1	100	89	175	18	150	8 x Ø 11	106.3	3.1
	33.7	25	85	12	65	4 x Ø 9	36.0	0.5
	42.4	32	95	12	75	4 x Ø 9	44.7	0.6
	48.3	40	100	12	80	4 x Ø 9	50.6	0.7
	60.3	52	110	14	90	4 x Ø 9	62.6	0.9
	76.1	59	140	16	115	4 x Ø 11	77.8	1.8
88.9	72	150	16	125	8 x Ø 11	90.6	2.0	
114.3	89	175	18	150	8 x Ø 11	115.4	3.1	

Flange form V

Model	DN	Dimensions in mm						Weight in kg
	in mm	Mb	D	F _G	k	d ₂	d ₄	
990.50 for pipes per DIN 11866 row A or DIN 11850 row 2	25	22	85	12	65	4 x Ø 9	32	0.4
	32	25	95	12	75	4 x Ø 9	38	0.5
	40	32	100	12	80	4 x Ø 9	44	0.6
	50	45	110	14	90	4 x Ø 9	56	0.9
	65	59	140	16	115	4 x Ø 11	72	1.7
	80	72	150	16	125	8 x Ø 11	87	2.0
990.50 for pipes per DIN 11866 row B or DIN EN ISO 1127 row 1	100	89	175	18	150	8 x Ø 11	106	3.1
	33.7	25	85	12	65	4 x Ø 9	35.7	0.4
	42.4	32	95	12	75	4 x Ø 9	44.4	0.5
	48.3	40	100	12	80	4 x Ø 9	50.3	0.6
	60.3	52	110	14	90	4 x Ø 9	62.3	0.9
	76.1	59	140	16	115	4 x Ø 11	77.5	1.7
88.9	72	150	16	125	8 x Ø 11	90.3	2.0	
114.3	89	175	18	150	8 x Ø 11	115.1	3.2	

Type of process connection: NEUMO BioConnect® connection

Pipe standard: Pipes per DIN 11866 row A and row B (or DIN 11850 und DIN EN ISO 1127)

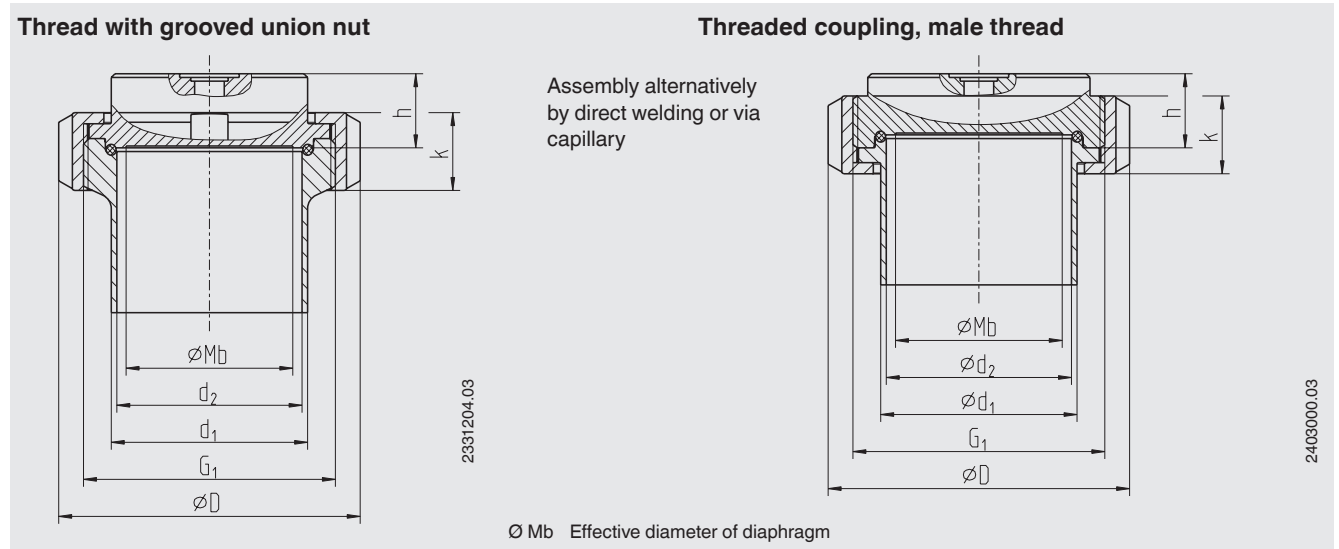

Thread with grooved union nut

Model	DN	Dimensions in mm							Weight in kg
	in mm	d ₁	d ₂	Mb	G1	D	k	h	
990.50 for pipes per DIN 11866 row A or DIN 11850 row 2	25	29	26	22	M42 x 2	55	18	20	0.3
	32	35	32	25	M52 x 2	65	19	20	0.4
	40	41	38	32	M56 x 2	70	21	20	0.5
	50	53	50	45	M68 x 2	82	21	20	0.7
	65	70	66	59	M90 x 3	105	27	20	1.3
	80	85	81	72	M100 x 3	115	27	20	1.6
990.50 for pipes per DIN 11866 row B or DIN EN ISO 1127 row 1	100	104	100	89	M130 x 4	145	29	20	2.6
	33.7	33.7	29.7	25	M42 x 2	55	18	20	0.3
	42.4	42.4	38.4	32	M52 x 2	65	19	20	0.4
	48.3	48.3	44.3	40	M56 x 2	70	21	20	0.5
	60.3	60.3	56.3	52	M68 x 2	82	21	20	0.7
	76.1	76.1	71.5	59	M90 x 3	105	27	20	1.3
88.9	88.9	84.3	72	M100 x 3	115	27	20	1.6	
114.3	114.3	109.1	89	M130 x 4	145	29	20	2.6	

Threaded coupling, male thread

Model	DN	Dimensions in mm							Weight in kg
	in mm	d ₁	d ₂	Mb	G1	D	k	h	
990.50 for pipes per DIN 11866 row A or DIN 11850 row 2	25	29	26	22	M42 x 2	55	18	20	0.2
	32	35	32	25	M52 x 2	65	19	20	0.25
	40	41	38	32	M56 x 2	70	21	20	0.3
	50	53	50	45	M68 x 2	82	21	20	0.5
	65	70	66	59	M90 x 3	105	27	28	0.9
	80	85	81	72	M100 x 3	115	27	28	1.1
990.50 for pipes per DIN 11866 row B or DIN EN ISO 1127 row 1	100	104	100	89	M130 x 4	145	29	30	1.9
	33.7	33.7	29.7	25	M42 x 2	55	18	20	0.2
	42.4	42.4	38.4	32	M52 x 2	65	19	20	0.25
	48.3	48.3	44.3	40	M56 x 2	70	21	20	0.3
	60.3	60.3	56.3	52	M68 x 2	82	21	20	0.5
	76.1	76.1	71.5	59	M90 x 3	105	27	28	0.9
88.9	88.9	84.3	72	M100 x 3	115	27	28	1.1	
114.3	114.3	109.1	89	M130 x 4	145	29	30	1.9	

Type of process connection: NEUMO BioConnect® connection

Pipe standard: Pipes per DIN 11866 row A and row B (or DIN 11850 und DIN EN ISO 1127)

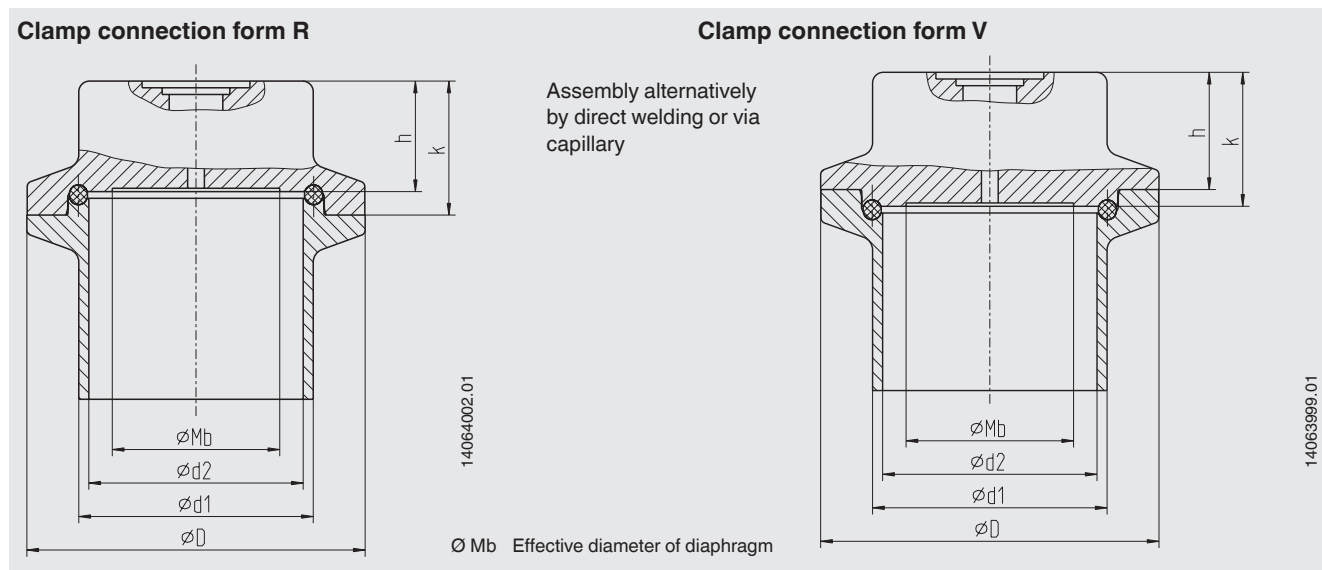





Clamp connection form R

Model	DN	Dimensions in mm						Weight in kg
	in mm	d ₁	d ₂	Mb	D	k	h	
990.50 for pipes per DIN 11866 row A or DIN 11850 row 2	25	29	26	22	50.4	16.5	20	0.3
	32	35	32	25	50.4	16.5	20	0.3
	40	41	38	32	64	16.5	20	0.4
	50	53	50	45	77.5	16.5	20	0.6
	65	70	66	59	91	16.5	20	0.8
	80	85	81	72	106	16.5	20	1.1
990.50 for pipes per DIN 11866 row B or DIN EN ISO 1127 row 1	100	104	100	89	119	16.5	20	1.4
	33.7	33.7	29.7	25	50.4	16.5	20	0.2
	42.4	42.4	38.4	32	50.4	16.5	20	0.2
	48.3	48.3	44.3	40	64	16.5	20	0.3
	60.3	60.3	56.3	52	77.5	16.5	20	0.6
	76.1	76.1	71.5	59	91	16.5	20	0.8
	88.9	88.9	84.3	72	106	16.5	20	1.0
	114.3	114.3	109.1	89	130	16.5	20	1.3

Clamp connection form V

Model	DN	Dimensions in mm						Weight in kg
	in mm	d ₁	d ₂	Mb	D	h	k	
990.50 for pipes per DIN 11866 row A or DIN 11850 row 2	25	29	26	22	50.4	17.5	20	0.3
	32	35	32	25	50.4	17.5	20	0.3
	40	41	38	32	64	17.5	20	0.4
	50	53	50	45	77.5	17.5	20	0.6
	65	70	66	59	91	17.5	20	0.8
	80	85	81	72	106	17.5	20	1.1
990.50 for pipes per DIN 11866 row B or DIN EN ISO 1127 row 1	100	104	100	89	119	17.5	20	1.4
	33.7	33.7	29.7	25	50.4	17.5	20	0.2
	42.4	42.4	38.4	32	50.4	17.5	20	0.2
	48.3	48.3	44.3	40	64	17.5	20	0.3
	60.3	60.3	56.3	52	77.5	17.5	20	0.6
	76.1	76.1	71.5	59	91	17.5	20	0.8
	88.9	88.9	84.3	72	106	17.5	20	1.0
	114.3	114.3	109.1	89	130	17.5	20	1.3

Approvals

Logo	Description	Country
	EU declaration of conformity Pressure equipment directive	European Union
	EAC Pressure equipment directive	Eurasian Economic Community
	3-A Sanitary Standard	USA
	EHEDG Hygienic Equipment Design	European Union
-	MTSCHS Permission for commissioning	Kazakhstan
-	CRN Safety (e.g. electr. safety, overpressure, ...)	Canada

Certificates (option)

- 2.2 test report per EN 10204 (e.g. state-of-the-art manufacturing, material proof, indication accuracy for diaphragm seal systems)
- 3.1 inspection certificate per EN 10204 (e.g. material proof for wetted metallic parts, indication accuracy for diaphragm seal systems)
- FDA conformity of the system fill fluid
- 3-A conformity of the diaphragm seal, based on a third party verification
- EHEDG conformity
- Manufacturer's declaration for food contact materials regarding regulation (EC) No. 1935/2004
- Others on request

Approvals and certificates, see website

Ordering information

Diaphragm seal:

Diaphragm seal model / Process connection (type and specification of process connection, pipe standard, pipe dimension) / Material (upper body, diaphragm) / Surface roughness of wetted parts / Connection to the measuring instrument / Level of cleanliness of wetted parts / Origin of wetted parts / Certificates

Diaphragm seal system:

Diaphragm seal model / Process connection (type and specification of process connection, pipe standard, pipe dimension) / Material (upper body, diaphragm) / Surface roughness of wetted parts / Pressure measuring instrument model (per data sheet) / Assembly (direct assembly, cooling element, capillary) / min. and max. process temperature / min. and max. ambient temperature / Vacuum service / System fill fluid / Certificates / Height difference / Level of cleanliness of wetted parts / Origin of wetted parts / Mounting bracket

© 03/2008 WIKA Alexander Wiegand SE & Co. KG, all rights reserved.
The specifications given in this document represent the state of engineering at the time of publishing.
We reserve the right to make modifications to the specifications and materials.

