

# Diaphragm seal with sterile connection For sanitary applications Model 990.24, VARIVENT® connection

WIKA data sheet DS 99.49



for further approvals  
see page 3

## Applications

- For installation into VARINLINE® access units
- Food and beverage production
- Dairies, dairy products
- Breweries
- Soft drink production

## Special features

- Quick cleaning of measuring point, without residue
- Suitable for SIP and CIP
- EHEDG certified and 3-A compliant

## Description

Diaphragm seals are used to protect the pressure measuring instrument from aggressive, adhesive, crystallising, corrosive, highly viscous, environmentally hazardous or toxic media. A diaphragm made of the appropriate material provides for the separation from the medium to be measured. Thus even the most difficult measuring requirements can be met by combining measuring instruments with diaphragm seals.

A fluid inside the system, which can be chosen to suit the particular application, hydraulically transmits the pressure to the measuring instrument.

Almost limitless application possibilities exist due to the large number of available variants, such as diaphragm seal designs or materials. The type of process connection (flange, threaded and sterile connection) and the basic method of manufacture are important design differentiation criteria.

For further technical information on diaphragm seals and diaphragm seal systems see IN 00.06 "Application, operating principle, designs".

The model 990.24 diaphragm seal with VARIVENT® connection is particularly suited for use in sterile processes and is



Diaphragm seal with sterile connection, model 990.24

adapted to the process via the VARINLINE® access unit. This enables a hygienic integration of measuring instruments into pipelines or, by means of VARINLINE® housing connection flanges, into tanks.

The diaphragm seal systems can withstand the cleaning vapour temperatures occurring in the SIP processes and thus ensure a sterile connection between the medium to be measured and the diaphragm seal.

Assembly of the diaphragm seal and measuring instrument is made via a direct assembly as standard or optionally via a cooling element or a flexible capillary.

For the material selection WIKA offers a variety of solutions, in which the upper body and the diaphragm are made of identical materials. Stainless steel 316L (1.4435) is used as standard material, other special materials are available on request.

Measuring systems with the model 990.24 WIKA diaphragm seal are successfully used in production and filling processes in the food, pharmaceutical and cosmetics industries.

## Standard version

### Type of process connection

VARIVENT® connection for VARINLINE® access unit and VARINLINE® housing connection flange, stainless steel 1.4435 (316L)

- Form F  
(installation Ø 50 mm, clamp Ø 66 mm) for VARINLINE® access unit DN 25, ISO 33.7 and 1" or
- Form N  
(installation Ø 68 mm, clamp Ø 84 mm) for VARINLINE® access unit DN 40 - DN 125, ISO 42.4 - 114.3 and 1 ½" - 6"

### Nominal pressure

PN 25 bar, observe the pressure rating of the VARINLINE® access unit!

### Measuring ranges

min. 0 ... 1 bar, max. 0 ... 25 bar  
(also vacuum and +/- measuring ranges)

### Material of upper body

CrNi-Stahl 1.4435 (316 L)

### Material of wetted parts

Diaphragm: Stainless steel 1.4435 (316L)

### Surface roughness of the wetted parts

Ra ≤ 0.76 µm (except for weld seam)

### Level of cleanliness of wetted parts

Oil and grease free per ASTM G93-03 level E (WIKA standard) and ISO 15001 (< 550 mg/m<sup>2</sup>)

### Connection to the measuring instrument

Axial weld-in connection

## Installation example

Diaphragm seal, sterile connection, model 990.24 with directly assembled pressure gauge on a VARINLINE® access unit

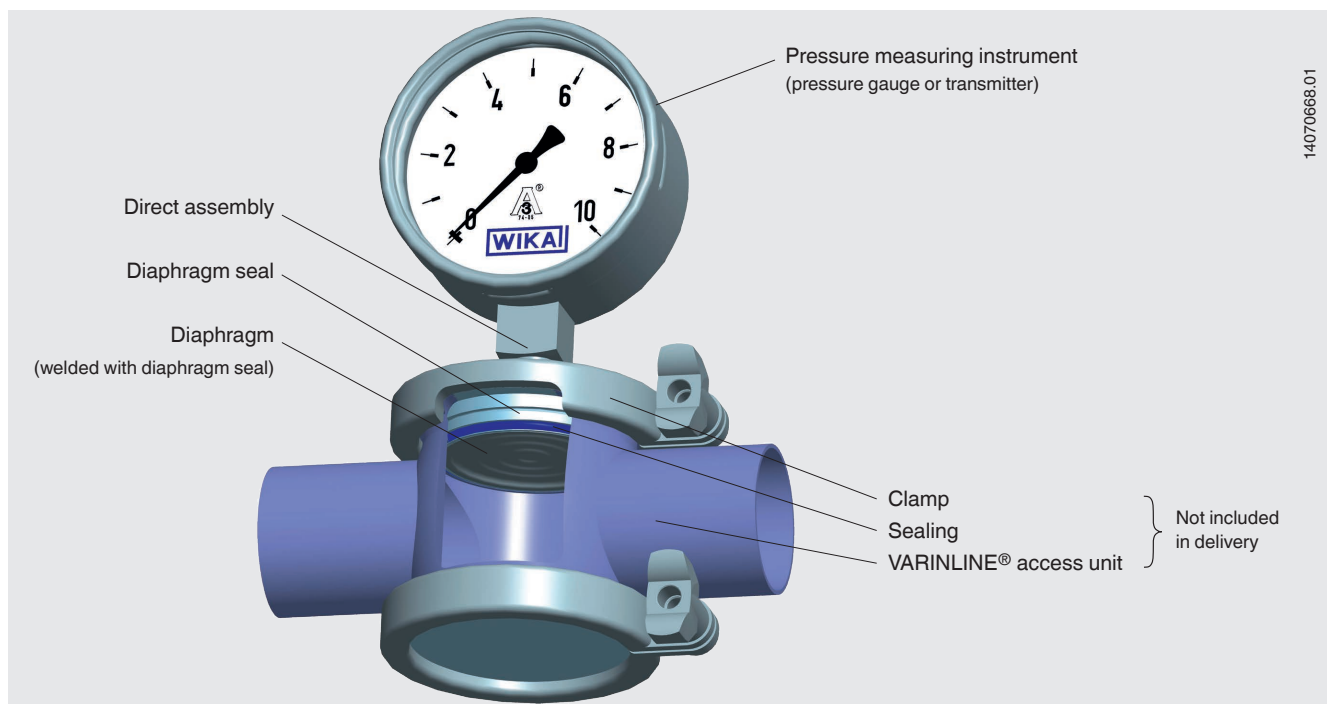

## Options

- Surface roughness of the wetted parts  
Ra ≤ 0.38 µm only with electropolished surface (except for weld seam)
- Connection to the measuring instrument  
G 1/2, G 1/4, 1/2 NPT or 1/4 NPT (female)
- Origin of wetted parts (EU, CH, USA)
- Marking of the diaphragm seal with 3-A standard

VARIVENT® and VARINLINE® are registered trademarks of the company GEA Tuchenhagen GmbH.

## Additional information for diaphragm seal systems

See Technical information IN 00.06 "Diaphragm seals - application, operating principle, designs"

- Pressure measuring instrument model
- Connection to the measuring instrument: Direct assembly (calibrated in vertical mounting position, process connection facing downwards)
- Process temperature
- Ambient temperature
- System fill fluid
  - Recommendation for the food and beverage production: Neobee® KN 59 (FDA 21 CFR 172.856, 21 CFR 174.5)
  - Recommendation for pharmaceutical and cosmetics applications: Medicinal white mineral oil KN 92 (FDA 21 CFR 172.878, 21 CFR 178.3620(a); USP, EP, JP)

## Options for diaphragm seal systems

- Connection to the measuring instrument via cooling element or capillary
- Vacuum service (suitable for vacuum operation)
- Higher level of cleanliness of wetted parts
  - Oil and grease free per ASTM G93-03 level D and ISO 15001 (< 220 mg/m<sup>2</sup>)
  - Oil and grease free per ASTM G93-03 level C and ISO 15001 (< 66 mg/m<sup>2</sup>)
- Height difference between measuring point and pressure measuring instrument with capillary in metre increments (max. 7 m with silicone oils/edible oils)
- Mounting bracket (required for connection to the measuring instrument via capillary, model 910.16, data sheet AC 09.07)
  - Form H per DIN 16281, 100 mm, aluminium, black
  - Form H per DIN 16281, 100 mm, stainless steel
  - Bracket for pipe mounting, for pipe Ø 20 ... 80 mm, steel

## Materials

Upper body	Wetted part Diaphragm
<b>Standard</b>	
Stainless steel 1.4435 (316L)	Stainless steel 1.4435 (316L)
<b>Option</b>	
Stainless steel 1.4435 (316L), electropolished <sup>1)</sup>	Stainless steel 1.4435 (316L), electropolished <sup>1)</sup>
Stainless steel 1.4539 (904L)	Stainless steel 1.4539 (904L)
Hastelloy C276 (2.4819)	Hastelloy C276 (2.4819)

<sup>1)</sup> Only in connection with a surface roughness of Ra ≤ 0.38 µm for the wetted parts

Further material combinations on request

## Approvals

- **EAC**, import certificate, customs union Russia/Belarus/Kazakhstan
- **CRN**, safety (e.g. electr. safety, overpressure, ...), Canada

## Certificates <sup>2)</sup>

- 2.2 test report per EN 10204 (e.g. state-of-the-art manufacturing, material proof, indication accuracy for diaphragm seal systems)
- 3.1 inspection certificate per EN 10204 (e.g. material proof for wetted metallic parts, indication accuracy for diaphragm seal systems)
- FDA conformity of the system fill fluid
- 3-A conformity of the diaphragm seal, based on a third party verification
- EHEDG conformity of the diaphragm seal (only in combination with EPDM O-ring from GEA Tuchenhausen GmbH, Germany)
- Manufacturer's declaration regarding EU regulation 1935/2004 EC
- Others on request

<sup>2)</sup> Option

Approvals and certificates, see website

## Dimensions in mm

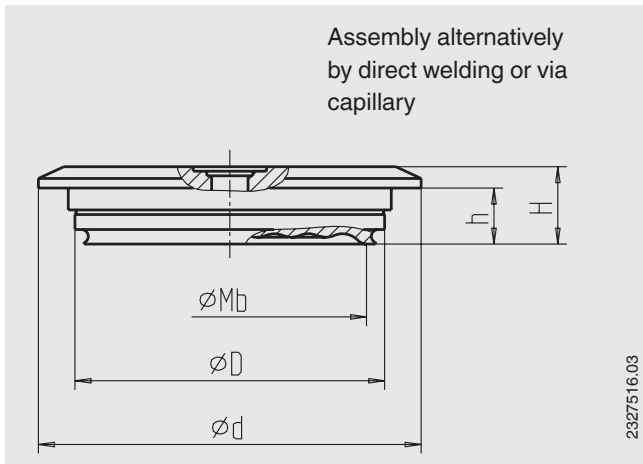

Access unit connection	Dimensions in mm					Weight in kg
	D	Mb	d	H	h	
Form F	50	40	66	17	12.3	0.29
Form N	68	60	84	17	12.3	0.51

### Ordering information

Diaphragm seal:

Diaphragm seal model / Process connection (type and specification of process connection) / Material (upper body, diaphragm) / Surface roughness of wetted parts / Connection to the measuring instrument / Level of cleanliness of wetted parts / Origin of wetted parts / Certificates

Diaphragm seal system:

Diaphragm seal model / Process connection (type and specification of process connection) / Material (upper body, diaphragm) / Surface roughness of wetted parts / Pressure measuring instrument model (per data sheet) / Assembly (direct assembly, cooling element, capillary) / min. and max. process temperature / min. and max. ambient temperature / Vacuum service / System fill fluid / Certificates / Height difference / Level of cleanliness of wetted parts / Origin of wetted parts / Mounting bracket

© 05/2007 WIKA Alexander Wiegand SE & Co. KG, all rights reserved.  
The specifications given in this document represent the state of engineering at the time of publishing.  
We reserve the right to make modifications to the specifications and materials.



**WIKAL Alexander Wiegand SE & Co. KG**  
Alexander-Wiegand-Straße 30  
63911 Klingenberg/Germany  
Tel. +49 9372 132-0  
Fax +49 9372 132-406  
info@wika.de  
www.wika.de