

Diaphragm seal with sterile connection

For sanitary applications

Model 990.51, aseptic connection per DIN 11864

WIKA data sheet DS 99.51



for further approvals
see page 7

Applications

- Food and beverage production
- Pharmaceutical industry, biotechnology industry, production of active ingredients
- Production of aseptic basic materials in the chemical industry

Special features

- Quick cleaning of measuring point, without residue
- Certified hygienic design
- Suitable for SIP and CIP
- EHEDG certified and 3-A compliant

Description

Diaphragm seals are used to protect the pressure measuring instrument from aggressive, adhesive, crystallising, corrosive, highly viscous, environmentally hazardous or toxic media. A diaphragm made of the appropriate material provides for the separation from the medium to be measured. Thus even the most difficult measuring requirements can be met by combining measuring instruments with diaphragm seals.

A fluid inside the system, which can be chosen to suit the particular application, hydraulically transmits the pressure to the measuring instrument.

Almost limitless application possibilities exist due to the large number of available variants, such as diaphragm seal designs or materials. The type of process connection (flange, threaded and sterile connection) and the basic method of manufacture are important design differentiation criteria.

For further technical information on diaphragm seals and diaphragm seal systems see IN 00.06 "Application, operating principle, designs".

The model 990.51 diaphragm seal with aseptic connection per DIN 11864 is ideally suited to fulfil the high standard



Diaphragm seal with sterile connection, model 990.51

Fig. left: With grooved union nut

Fig. right: Flange connection

Fig. bottom: Clamp connection

requirements of sanitary applications. It can be optimally integrated into aseptic processes, fulfils all hygienic design requirements and is EHEDG certified. The diaphragm seal systems can withstand the cleaning vapour temperatures occurring in the SIP processes and thus ensure a sterile connection between the medium to be measured and the diaphragm seal.

Assembly of the diaphragm seal and measuring instrument is made via a direct assembly as standard or optionally via a cooling element or a flexible capillary.

For the material selection WIKA offers a variety of solutions, in which the upper body and the diaphragm are made of identical materials. Stainless steel 316L (1.4435) is used as standard material, other special materials are available on request.

Measuring systems with the model 990.51 WIKA diaphragm seal are successfully used in pharmaceutical, biotechnology, aseptic food production and life science industries.

Standard version

Process connection type

Aseptic connection per DIN 11864, sealing form A

- Aseptic threaded pipe connection per DIN 11864-1
- Aseptic flange connection per DIN 11864-2
- Aseptic clamp connection per DIN 11864-3

For pipes per DIN 11866 row A and row B (or DIN 11850 and DIN EN ISO 1127)

For exact designs and nominal widths see tables on page 4 to 6

Nominal pressure

see tables on page 4 to 6

Measuring ranges

Threaded connection: 0 ... 0.6 bar to 0 ... 40 bar (to DN 40)
0 ... 0.6 bar to 0 ... 25 bar (from DN 50)

Flange connection: 0 ... 0.6 bar to 0 ... 25 bar (to DN 40)
0 ... 0.6 bar to 0 ... 16 bar (from DN 50)

Clamp connection: 0 ... 0.6 bar to 0 ... 40 bar (to DN 40)
0 ... 0.6 bar to 0 ... 25 bar (to DN 65)
0 ... 0.6 bar to 0 ... 16 bar (from DN 80)

(also vacuum and +/- measuring ranges)

Material of upper body

Stainless steel 1.4435 (316 L)

Material of wetted parts

Diaphragm: Stainless steel 1.4435 (316L)

Surface roughness of wetted parts

$Ra \leq 0.76 \mu\text{m}$ (except for weld seam)

Level of cleanliness of wetted parts

Oil and grease free per ASTM G93-03 level E (WIKA standard) and ISO 15001 ($< 550 \text{ mg/m}^2$)

Connection to the measuring instrument

Axial weld-in connection

Options

- Process connection
Other nominal widths and aseptic connections on request
- Higher nominal pressures on request
- Surface roughness of wetted parts
 $Ra \leq 0.38 \mu\text{m}$ per ASME BPE SF4, only with electropolished surface (except for weld seam)
- Connection to the measuring instrument
G 1/2, G 1/4, 1/2 NPT or 1/4 NPT (female)
- Origin of wetted parts (EU, CH, USA)
- Marking of the diaphragm seal in accordance with the applicable 3-A standard

Installation example

Diaphragm seal, sterile connection, model 990.51 with directly assembled pressure gauge on a pipe socket

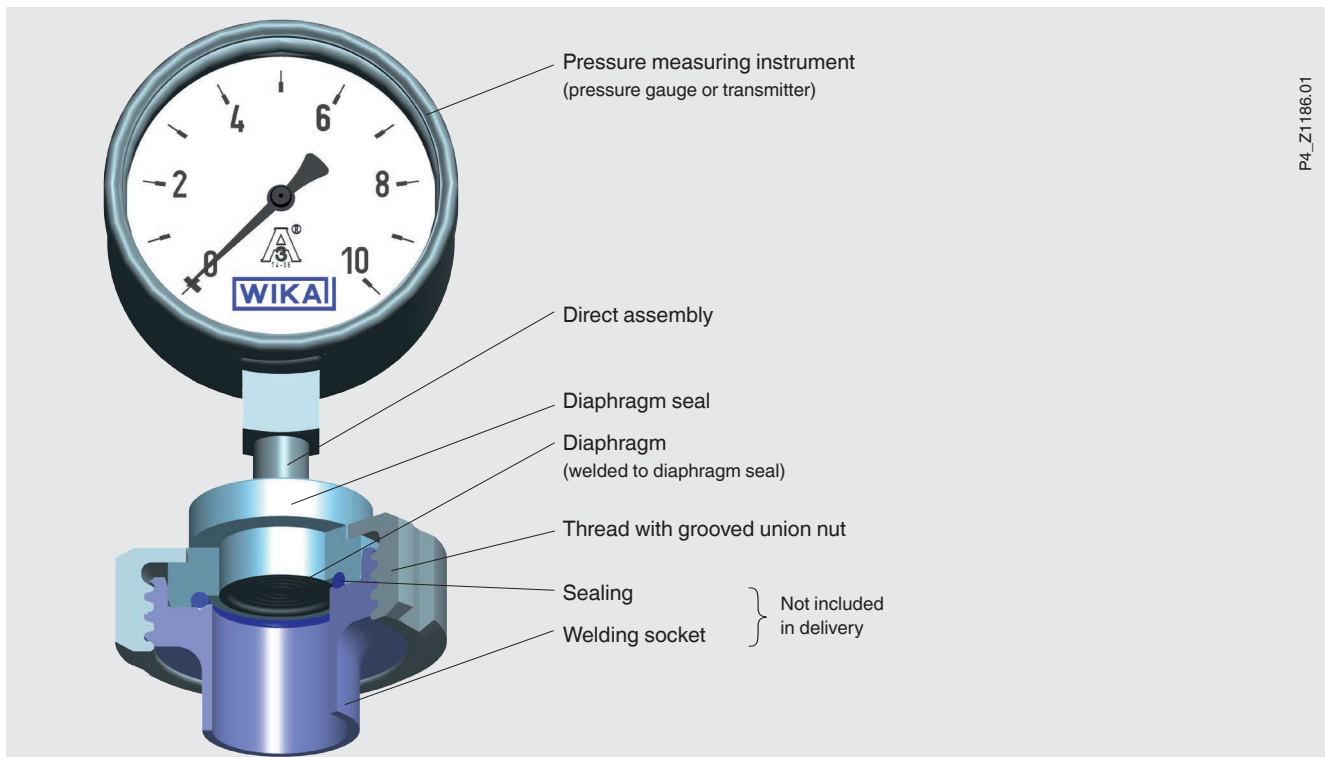

Additional information for diaphragm seal systems

See Technical information IN 00.06 “Diaphragm seals, application, operating principle, designs”

- Pressure measuring instrument model
- Connection to the measuring instrument: Direct assembly (calibrated in vertical mounting position, process connection facing downwards)
- Process temperature
- Ambient temperature
- System fill fluid
 - Recommendation for the food and beverage production: Neobee® KN 59 (FDA 21 CFR 172.856, 21 CFR 174.5)
 - Recommendation for pharmaceutical and cosmetics applications: Medicinal white mineral oil KN 92 (FDA 21 CFR 172.878, 21 CFR 178.3620(a); USP, EP)

Options for diaphragm seal systems

- Connection to the measuring instrument via cooling element or capillary
- Suitable for vacuum operation
- Higher level of cleanliness of wetted parts
Oil and grease free per ASTM G93-03 level C and ISO 15001 (< 66 mg/m²)
- Height difference between measuring point and pressure measuring instrument with capillary in metre increments (max. 7 m with silicone oils/edible oils)
- Mounting bracket (required for connection to the measuring instrument via capillary, model 910.16, data sheet AC 09.07)
 - Form H per DIN 16281, 100 mm, aluminium, black
 - Form H per DIN 16281, 100 mm, stainless steel
 - Bracket for pipe mounting, for pipe Ø 20 ... 80 mm, steel

Materials

Upper body	Wetted part: Diaphragm
Standard	
Stainless steel 1.4435 (316L)	Stainless steel 1.4435 (316L)
Option	
Stainless steel 1.4435 (316L), electropolished	Stainless steel 1.4435 (316L), electropolished
Stainless steel 1.4539 (904L)	Stainless steel 1.4539 (904L)
Hastelloy C276 (2.4819)	Hastelloy C276 (2.4819)
Hastelloy C22 (2.4602)	Hastelloy C22 (2.4602)

Further material combinations on request

Dimensions in mm

Type of process connection: Aseptic threaded pipe connection DIN 11864-1 form A (O-ring)

Specification of the process connection: With collar connecting sleeve and grooved union nut or with threaded coupling

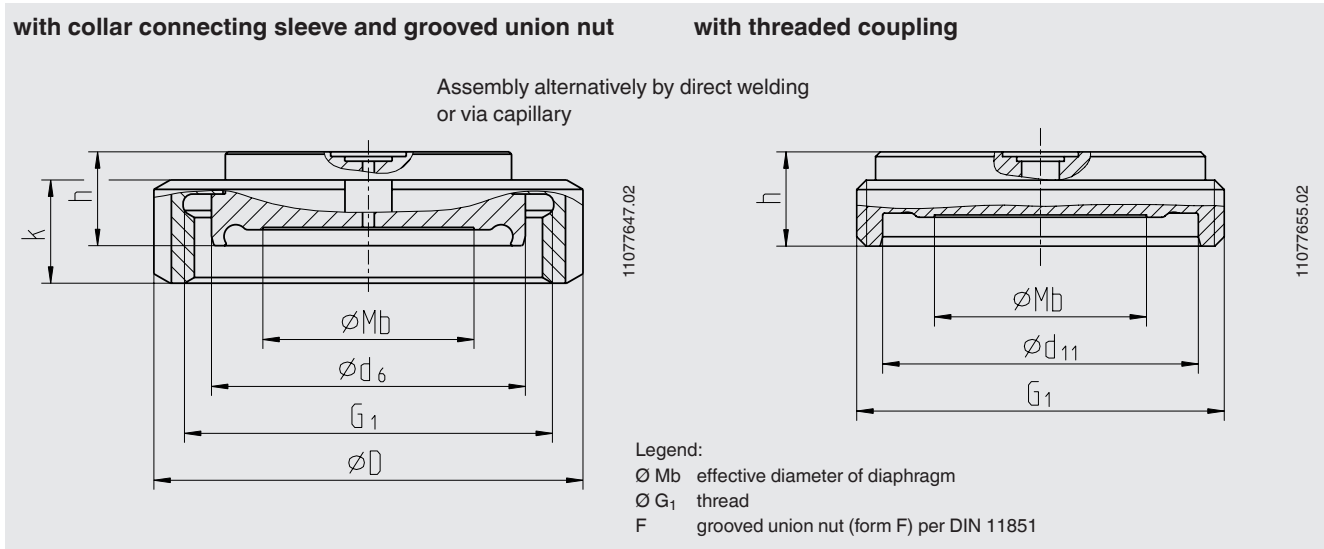

Pipe standard: Pipes per DIN 11866 row A or DIN 11850 row 2

DN	For pipe Outer \varnothing x wall thickness	PN ¹⁾	Dimensions in mm								Weight in kg		
			Mb	d ₆	d ₁₁	G ₁	h	F	D	k	Aseptic O-ring	Collar connecting sleeve	Threaded coupling
25	29 x 1.5	40	22	42.9	43	RD 52 x 1/6	20	DN 25	63	21	28 x 3.5	1.0	0.9
32	35 x 1.5	40	25	48.9	49	RD 58 x 1/6	20	DN 32	70	21	34 x 5	1.2	1.2
40	41 x 1.5	40	35	54.9	55	RD 65 x 1/6	20	DN 40	78	21	40 x 5	1.5	1.5
50	53 x 1.5	25	45	66.9	67	RD 78 x 1/6	20	DN 50	92	22	52 x 5	2.2	2.3
65	70 x 2	25	60	84.9	85	RD 95 x 1/6	20	DN 65	112	25	68 x 5	3.6	3.6
80	85 x 2	25	72	98.9	99	RD 110 x 1/4	20	DN 80	127	29	83 x 5	5.0	4.9
100	104 x 2	25	90	118.9	119	RD 130 x 1/4	20	DN 100	148	31	102 x 5	7.1	7.1

Pipe standard: Pipes per DIN 11866 row B or DIN ISO 1127 row 1

DN	For pipe Outer \varnothing x wall thickness	PN ¹⁾	Dimensions in mm								Weight in kg		
			Mb	d ₆	d ₁₁	G ₁	h	F	D	k	Aseptic O-ring	Collar connecting sleeve	Threaded coupling
26.9	26.9 x 1.6	40	22	42.9	43	RD 52 x 1/6	20	DN 25	63	21	26 x 3.5	1.0	0.9
33.7	33.7 x 2.0	40	25	48.9	49	RD 58 x 1/6	20	DN 32	70	21	32 x 5	1.2	1.2
42.4	42.4 x 2.0	25	35	54.9	55	RD 65 x 1/6	20	DN 40	78	21	40.5 x 5	1.5	1.5
48.3	48.3 x 2.0	25	45	66.9	67	RD 78 x 1/6	20	DN 50	92	22	46.5 x 5	2.2	2.3
60.3	60.3 x 2.0	25	60	84.9	85	RD 95 x 1/6	20	DN 65	112	25	58.5 x 5	3.6	3.6
76.1	76.1 x 2.0	25	72	98.9	99	RD 110 x 1/4	20	DN 80	127	29	73.5 x 5	5.0	4.9
88.9	88.9 x 2.3	25	90	118.9	119	RD 130 x 1/4	20	DN 100	148	31	86.5 x 5	7.1	7.1

Pipe standard: Pipes per DIN 11866 row C or ASME BPE 1997

DN	For pipe Outer \varnothing x wall thickness	PN 1)	Dimensions in mm								Weight in kg		
			Mb	d ₆	d ₁₁	G ₁	h	F	D	k	Aseptic O-ring	Collar connecting sleeve	Threaded coupling
1"	25.4 x 1.65	40	22	42.9	43	RD 52 x 1/6	20	DN 25	63	21	24 x 3.5	1.0	0.9
1 1/2"	42.4 x 1.65	40	32	54.9	55	RD 65 x 1/6	20	DN 40	78	21	37 x 5	1.5	1.5
2"	48.3 x 1.65	25	45	66.9	67	RD 78 x 1/6	20	DN 50	92	22	50 x 5	2.2	2.3
2 1/2"	60.3 x 1.65	25	52	84.9	85	RD 95 x 1/6	20	DN 65	112	25	62 x 5	3.6	3.6
3"	76.1 x 1.65	25	60	98.9	99	RD 110 x 1/4	20	DN 80	127	29	75 x 5	5.0	4.9
4"	88.9 x 2.11	25	90	118.9	119	RD 130 x 1/4	20	DN 100	148	31	100 x 5	7.1	7.1

1) Permissible pressure in bar; these pressures may only be applied when using suitable sealing materials up to a temperature from -10 ... +140 °C.

Type of process connection: Aseptic flange connection DIN 11864-2 form A (O-ring)
 Specification of the process connection: With aseptic flange with groove or with flange with notch

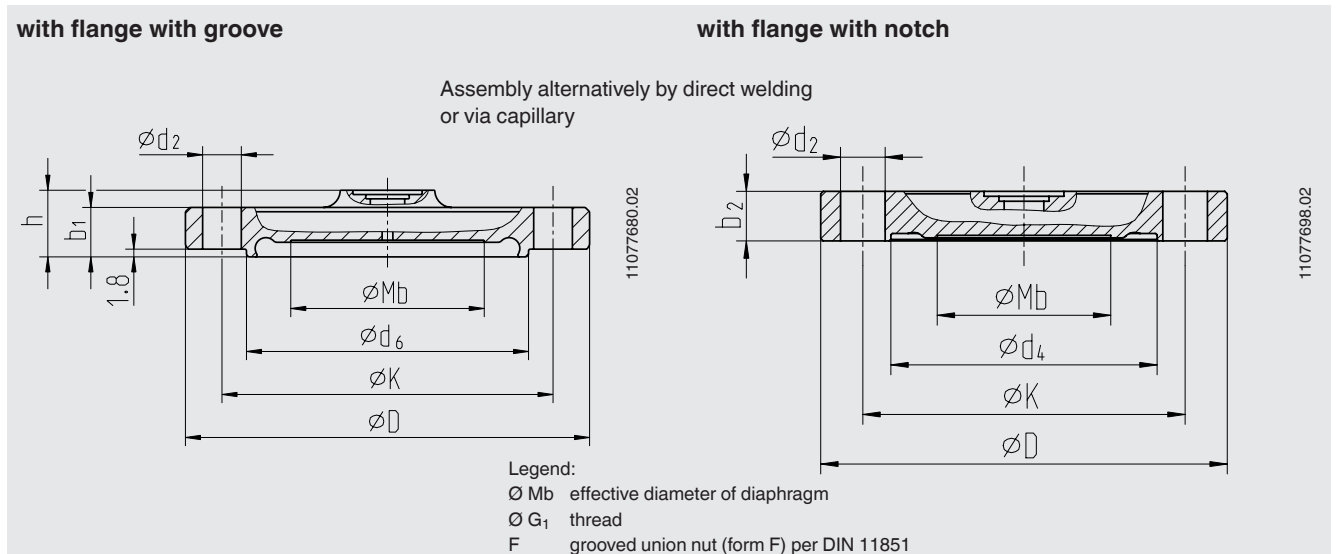

Pipe standard: Pipes per DIN 11866 row A or DIN 11850 row 2

DN	For pipe Outer Ø x wall thickness	PN ¹⁾	Dimensions in mm										Weight in kg		
			Mb	d ₆	d ₄	K	D	h	b ₁	b ₂	d ₂	Aseptic O-ring	Flange with groove	Flange with notch	
25	29 x 1.5	25	22	38.3	38.4	53	70	15.5	11.5	10	4 x Ø 9	28 x 3.5	1.4	1.2	
32	35 x 1.5	25	25	47.6	47.7	59	76	15.5	11.5	10	4 x Ø 9	34 x 5	1.7	1.5	
40	41 x 1.5	25	35	53.6	53.7	65	82	15.5	11.5	10	4 x Ø 9	40 x 5	1.9	1.7	
50	53 x 1.5	16	45	65.6	65.7	77	94	15.5	11.5	10	4 x Ø 9	52 x 5	2.6	2.2	
65	70 x 2	16	60	81.6	81.7	95	113	15.5	11.5	10	8 x Ø 9	68 x 5	3.7	3.2	
80	85 x 2	16	72	97.6	97.7	112	133	17.5	13.5	12	8 x Ø 11	83 x 5	6.0	5.3	
100	104 x 2	16	90	116.6	116.7	137	159	19.5	15.5	14	8 x Ø 11	102 x 5	9.8	8.9	

Pipe standard: Pipes per DIN 11866 row B or DIN ISO 1127 row 1

DN	For pipe Outer Ø x wall thickness	PN ¹⁾	Dimensions in mm										Weight in kg		
			Mb	d ₆	d ₄	K	D	h	b ₁	b ₂	d ₂	Aseptic O-ring	Flange with groove	Flange with notch	
26.9	26.9 x 1.6	25	22	36.0	36.1	52	69	15.5	11.5	10	4 x Ø 9	26 x 3.5	1.4	1.2	
33.7	33.7 x 2.0	25	25	45.3	45.4	57	74	15.5	11.5	10	4 x Ø 9	32 x 5	1.6	1.4	
42.4	42.4 x 2.0	16	35	54.0	54.1	65	82	15.5	11.5	10	4 x Ø 9	40.5 x 5	1.9	1.7	
48.3	48.3 x 2.0	16	40	59.9	60.0	71	88	15.5	11.5	10	4 x Ø 9	46.5 x 5	2.2	1.9	
60.3	60.3 x 2.0	16	52	71.9	72.0	85	103	15.5	11.5	10	8 x Ø 9	58.5 x 5	3.1	2.7	
76.1	76.1 x 2.0	16	60	88.1	88.1	104	125	17.5	13.5	12	8 x Ø 11	73.5 x 5	5.3	4.7	
88.9	88.9 x 2.3	16	72	100.9	101.0	116	137	17.5	13.5	12	8 x Ø 11	86.5 x 5	6.4	5.7	

Pipe standard: Pipes per DIN 11866 row C or ASME BPE 1997

DN	For pipe Outer Ø x wall thickness	PN ¹⁾	Dimensions in mm										Weight in kg		
			Mb	d ₆	d ₄	K	D	h	b ₁	b ₂	d ₂	Aseptic O-ring	Flange with groove	Flange with notch	
1"	25.4 x 1.65	25	22	34.3	34.4	49	66	15.5	11.5	10	4 x Ø 9	24 x 3.5	1.0	0.9	
1 ½"	38.1 x 1.65	25	32	50.4	50.4	62	79	15.5	11.5	10	4 x Ø 9	37 x 5	1.5	1.5	
2"	50.8 x 1.65	16	45	63.4	63.5	75	92	15.5	11.5	10	4 x Ø 9	50 x 5	2.2	2.3	
2 ½"	63.5 x 1.65	16	52	75.8	75.9	89	107	15.5	11.5	10	4 x Ø 9	62 x 5	3.6	3.6	
3"	76.2 x 1.65	16	60	89.5	89.6	104	125	17.5	13.5	12	8 x Ø 11	75 x 5	5.0	4.9	
4"	101.6 x 2.11	16	90	114.2	114.3	135	157	19.5	15.5	14	8 x Ø 11	100 x 5	7.1	7.1	

1) Permissible pressure in bar; these pressures may only be applied when using suitable sealing materials up to a temperature from -10 ... +140 °C.

Type of process connection: Aseptik clamp connection DIN 11864-3 form A (O-ring)

Specification of the process connection: With clamp with groove or with clamp with notch

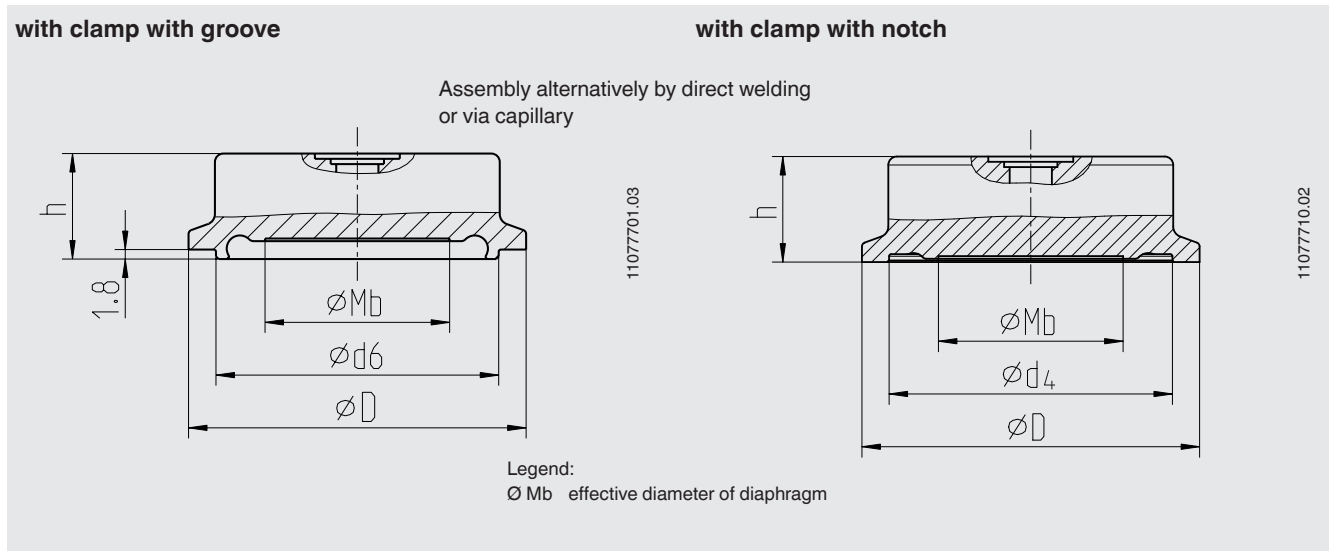

Pipe standard: Pipes per DIN 11866 row A or DIN 11850 row 2

DN	For pipe Outer Ø x wall thickness	PN ¹⁾	Dimensions in mm						Aseptic O-ring	Weight in kg
			Mb	d ₆	d ₄	D	h			
25	29 x 1.5	40	22	38.3	38.4	50.5	20	28 x 3.5	0.7	
32	35 x 1.5	40	25	47.6	47.7	50.5	20	34 x 5	1.1	
40	41 x 1.5	40	35	53.6	53.7	64	20	40 x 5	1.4	
50	53 x 1.5	25	45	65.6	65.7	77.5	20	52 x 5	2.2	
65	70 x 2	25	60	81.6	81.7	91	20	68 x 5	3.3	
80	85 x 2	16	72	97.6	97.7	106	20	83 x 5	4.8	
100	104 x 2	16	90	116.6	116.7	130	21.5	102 x 5	7.3	

Pipe standard: Pipes per DIN 11866 row B or DIN ISO 1127 row 1



DN	For pipe Outer Ø x wall thickness	PN ¹⁾	Dimensions in mm						Aseptic O-ring	Weight in kg
			Mb	d ₆	d ₄	D	h			
26.9	26.9 x 1.6	40	22	36.0	36.1	50.5	20	26 x 3.5	0.7	
33.7	33.7 x 2.0	40	25	45.3	45.3	50.5	20	32 x 5	1.0	
42.4	42.4 x 2.0	25	35	54.0	54.1	64	20	40.5 x 5	1.5	
48.3	48.3 x 2.0	25	40	59.9	60.0	64	20	46.5 x 5	1.8	
60.3	60.3 x 2.0	25	52	71.9	72.0	91	20	58.5 x 5	2.6	
76.1	76.1 x 2.0	16	60	88.1	88.2	106	20	73.5 x 5	3.9	
88.9	88.9 x 2.3	16	72	100.9	101.0	130	22.5	86.5 x 5	5.8	

Pipe standard: Pipes per DIN 11866 row C or ASME BPE 1997

DN	For pipe Outer Ø x wall thickness	PN ¹⁾	Dimensions in mm						Aseptic O-ring	Weight in kg
			Mb	d ₆	d ₄	D	h			
1"	25.4 x 1.65	40	22	34.3	34.4	50.5	20	24 x 3.5	0.6	
1 ½"	38.1 x 1.65	40	32	50.4	50.5	64	20	37 x 5	1.3	
2"	50.8 x 1.65	25	45	63.4	63.5	77.5	20	50 x 5	2.0	
2 ½"	63.5 x 1.65	25	52	75.8	75.9	91	20	62 x 5	2.9	
3"	76.2 x 1.65	16	60	89.5	89.6	106	20	75 x 5	4.0	
4"	101.6 x 2.11	16	90	114.2	114.3	130	21	100 x 5	6.9	

¹⁾ Permissible pressure in bar; these pressures may only be applied when using suitable sealing materials up to a temperature from -10 ... +140 °C.

Approvals

Logo	Description	Country
	EU declaration of conformity Pressure equipment directive	European Union
	3-A Sanitary Standard	USA
	EHEDG Hygienic Equipment Design	European Union
-	MTSCHS Permission for commissioning	Kazakhstan
-	CRN Safety (e.g. electr. safety, overpressure, ...)	Canada

Certificates (option)

- 2.2 test report per EN 10204 (e.g. state-of-the-art manufacturing, material proof, indication accuracy for diaphragm seal systems)
- 3.1 inspection certificate per EN 10204 (e.g. material proof for wetted metallic parts, indication accuracy for diaphragm seal systems)
- FDA conformity of the system fill fluid
- 3-A conformity of the diaphragm seal, based on a third party verification
- EHEDG conformity
- Manufacturer's declaration for food contact materials regarding regulation (EC) No. 1935/2004
- Others on request

Approvals and certificates, see website

Ordering information

Diaphragm seal:

Diaphragm seal model / Process connection (type and specification of process connection, pipe standard, pipe dimension) / Material (upper body, diaphragm) / Surface roughness of wetted parts / Connection to the measuring instrument / Level of cleanliness of wetted parts / Origin of wetted parts / Certificates

Diaphragm seal system:

Diaphragm seal model / Process connection (type and specification of process connection, pipe standard, pipe dimension) / Material (upper body, diaphragm) / Surface roughness of wetted parts / Pressure measuring instrument model (per data sheet) / Assembly (direct assembly, cooling element, capillary) / min. and max. process temperature / min. and max. ambient temperature / Vacuum service / System fill fluid / Certificates / Height difference / Level of cleanliness of wetted parts / Origin of wetted parts / Mounting bracket

© 11/2006 WIKA Alexander Wiegand SE & Co. KG, all rights reserved.
The specifications given in this document represent the state of engineering at the time of publishing.
We reserve the right to make modifications to the specifications and materials.

